

NOVASONAR - Invisible loudspeaker

AK-Series



Power handling: 30 Watts	
Dimensions: Min. 500 mm x 625 mm	
AK 30 (Ext. DSP recommended)	2
AK 30 / PN (Incl. frequency crossover)	3

Power handling: 60 Watts	
Dimensions: Min. 500 mm x 625 mm	
AK 60 (Ext. DSP recommended)	4
AK 60 / PN (Incl. frequency crossover)	5
AK 60 Stereo (Ext. DSP recommended)	6
AK 60 Stereo / PN (Incl. frequency crossover)	7

PN = Integrated frequency crossover

Please click on the products to open the respective **data specification sheet**

www.novasonar.de

specification sheets

NOVASONAR AK 30

Invisible sound system for acoustic ceilings



Building material and the sound system from a single production source



Available in the following acoustic boards

Expanded glass granulate, mineral wool, glass wool, wood wool, chipped wood, etc. in all usual versions

Description / Technical data

Flat-panel loudspeaker on the principle of the bending wave transducer with a flat panel membrane, which is brought to vibration by electrical exciters mounted to the back.

The loudspeaker comprises a conventional acoustic board, e.g. made of expanded glass granulate, mineral wool, glass wool, wood wool, particle wood etc. with a factory-integrated flat-panel loudspeaker.

The acoustic board is stripped down to a minimum thickness on the back in the area of the loudspeaker membrane by means of milling and thus causes sound-neutrality.

Materials and assembly do not differ from other construction materials used and as a result, there are no „alien bodies“ in the acoustic ceiling.

Factory integration of the flat-panel loudspeaker in the building material precludes any errors in installation and guarantees continuously assembly and processing technology in drywall work without material change, therefore ensuring smooth progress on the building site.

The surface can be coated with all usual acoustic coatings.

Dimensions (standard):	Minimum 500 mm x 625 mm
Building material:	Acoustic board
Frequency response:	80 Hz – 20000 Hz
EQ:	External
Dispersion:	180° x 180°
Power handling:	30 W / 8 Ω
Optional:	70/100 V
Sensitivity:	80 dB (1 w / 1 m)
Max. SPL:	95 dB (1 m)

Manufacturer: ML-Audio und Carbons GmbH
Model: Novasonar AK 30

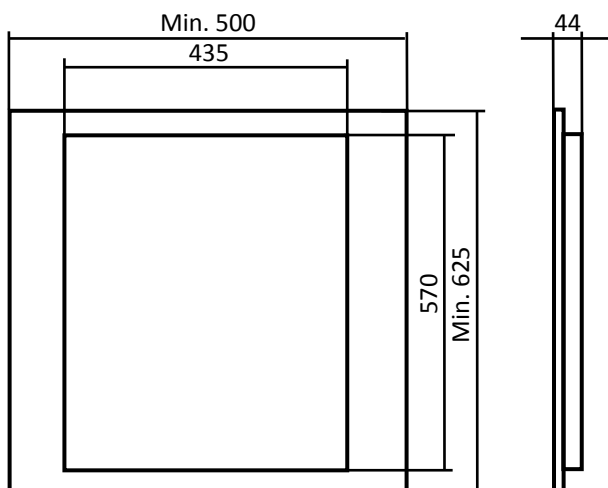
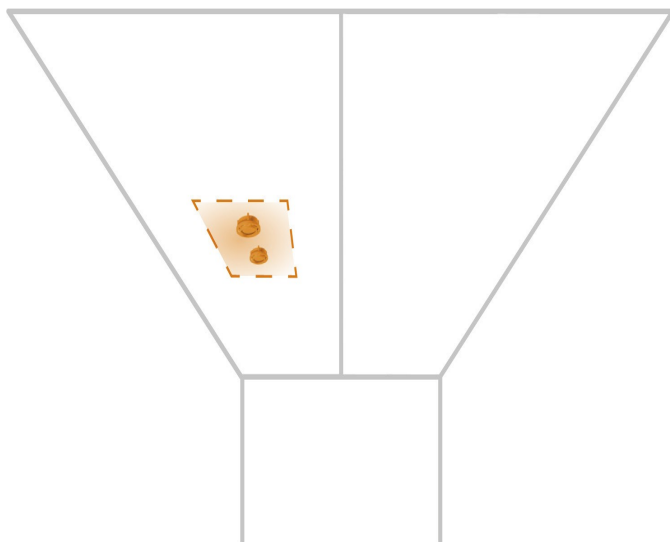

[Back to contents](#)

All products subject to technical modification without prior notice. Errors excepted.

NOVASONAR AK 30 / PN

Invisible sound system for acoustic ceilings



Building material and the sound system from a single production source



Available in the following acoustic boards

Expanded glass granulate, mineral wool, glass wool, wood wool, chipped wood, etc. in all usual versions

Description / Technical data

Flat-panel loudspeaker on the principle of the bending wave transducer with a flat panel membrane, which is brought to vibration by electrical exciters mounted to the back and with an integrated frequency crossover/filter.

The loudspeaker comprises a conventional acoustic board, e.g. made of expanded glass granulate, mineral wool, glass wool, wood wool, particle wood etc. with a factory-integrated flat-panel loudspeaker.

The acoustic board is stripped down to a minimum thickness on the back in the area of the loudspeaker membrane by means of milling and thus causes sound-neutrality.

Materials and assembly do not differ from other construction materials used and as a result, there are no „alien bodies“ in the acoustic ceiling.

Factory integration of the flat-panel loudspeaker in the building material precludes any errors in installation and guarantees continuously assembly and processing technology in drywall work without material change, therefore ensuring smooth progress on the building site.

The surface can be coated with all usual acoustic coatings.

Dimensions (standard):	Minimum 500 mm x 625 mm
Building material:	Acoustic board
Frequency response:	80 Hz – 20000 Hz
EQ:	PN– integrated crossover
Dispersion:	180° x 180°
Power handling:	30 W / 8 Ω
Optional:	70/100 V
Sensitivity:	80 dB (1 w / 1 m)
Max. SPL:	95 dB (1 m)

Manufacturer: ML-Audio und Carbons GmbH
Model: Novasonar AK 30 / PN

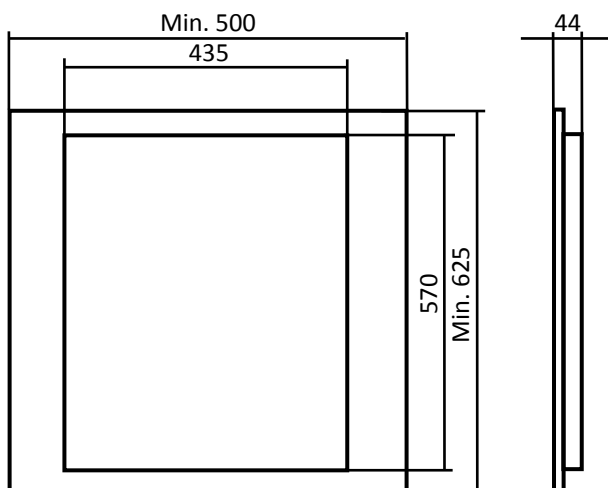
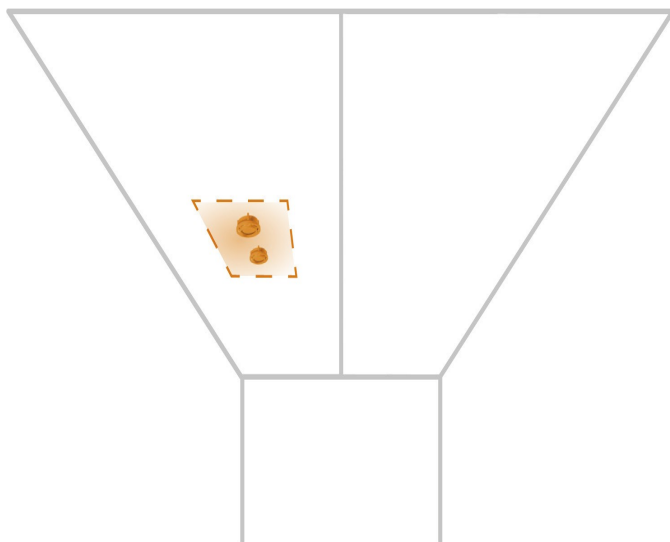

[Back to contents](#)

All products subject to technical modification without prior notice. Errors excepted.

NOVASONAR AK 60

Invisible sound system for acoustic ceilings



Building material and the sound system from a single production source



Available in the following acoustic boards

Expanded glass granulate, mineral wool, glass wool, wood wool, chipped wood, etc. in all usual versions

Description / Technical data

Flat-panel loudspeaker on the principle of the bending wave transducer with a flat panel membrane, which is brought to vibration by electrical exciters mounted to the back.

The loudspeaker comprises a conventional acoustic board, e.g. made of expanded glass granulate, mineral wool, glass wool, wood wool, particle wood etc. with a factory-integrated flat-panel loudspeaker.

The acoustic board is stripped down to a minimum thickness on the back in the area of the loudspeaker membrane by means of milling and thus causes sound-neutrality.

Materials and assembly do not differ from other construction materials used and as a result, there are no „alien bodies“ in the acoustic ceiling.

Factory integration of the flat-panel loudspeaker in the building material precludes any errors in installation and guarantees continuously assembly and processing technology in drywall work without material change, therefore ensuring smooth progress on the building site.

The surface can be coated with all usual acoustic coatings.

Dimensions (standard):	Minimum 500 mm x 625 mm
Building material:	Acoustic board
Frequency response:	80 Hz – 20000 Hz
EQ:	External
Dispersion:	180° x 180°
Power handling:	60 W / 4 Ω (Optional 16 Ω)
Optional:	70/100 V
Sensitivity:	83 dB (1 w / 1 m)
Max. SPL:	101 dB (1 m)

Manufacturer: ML-Audio und Carbons GmbH
Model: Novasonar AK 60

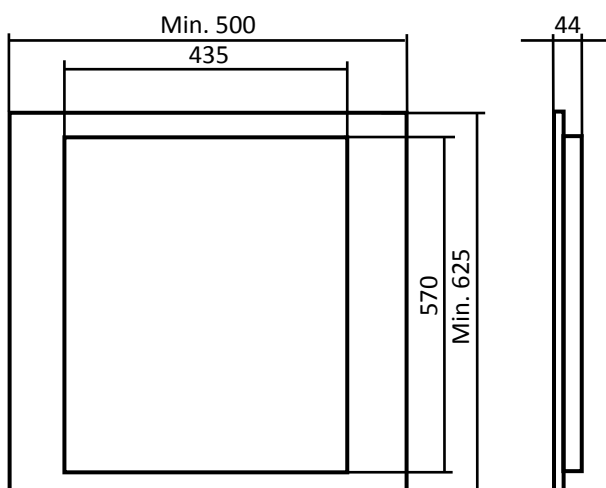
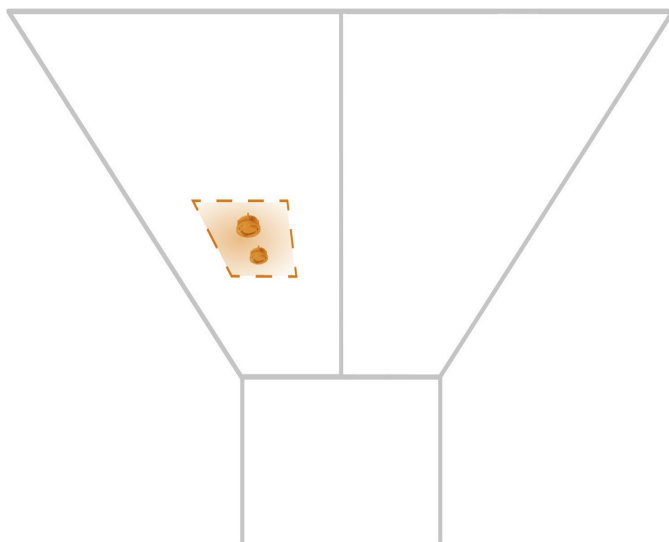

[Back to contents](#)

All products subject to technical modification without prior notice. Errors excepted.

NOVASONAR AK 60 / PN

Invisible sound system for acoustic ceilings



Building material and the sound system from a single production source



Available in the following acoustic boards

Expanded glass granulate, mineral wool, glass wool, wood wool, chipped wood, etc. in all usual versions

Description / Technical data

Flat-panel loudspeaker on the principle of the bending wave transducer with a flat panel membrane, which is brought to vibration by electrical exciters mounted to the back and with an integrated frequency crossover/filter.

The loudspeaker comprises a conventional acoustic board, e.g. made of expanded glass granulate, mineral wool, glass wool, wood wool, particle wood etc. with a factory-integrated flat-panel loudspeaker.

The acoustic board is stripped down to a minimum thickness on the back in the area of the loudspeaker membrane by means of milling and thus causes sound-neutrality.

Materials and assembly do not differ from other construction materials used and as a result, there are no „alien bodies“ in the acoustic ceiling.

Factory integration of the flat-panel loudspeaker in the building material precludes any errors in installation and guarantees continuously assembly and processing technology in drywall work without material change, therefore ensuring smooth progress on the building site.

The surface can be coated with all usual acoustic coatings.

Dimensions (standard):	Minimum 500 mm x 625 mm
Building material:	Acoustic board
Frequency response:	80 Hz – 20000 Hz
EQ:	PN– integrated crossover
Dispersion:	180° x 180°
Power handling:	60 W / 4 Ω
Optional:	70/100 V
Sensitivity:	83 dB (1 w / 1 m)
Max. SPL:	101 dB (1 m)

Manufacturer: ML-Audio und Carbons GmbH
Model: Novasonar AK 60 / PN

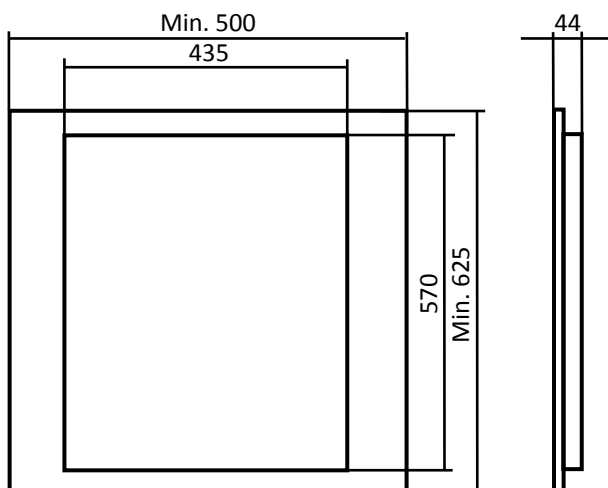
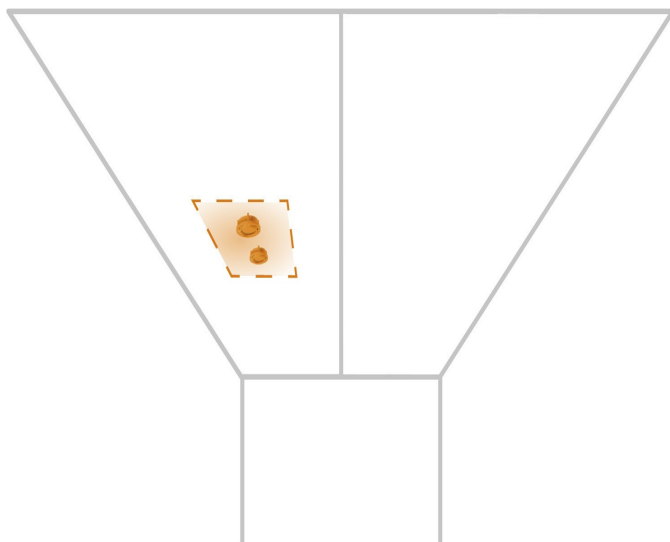

[Back to contents](#)

All products subject to technical modification without prior notice. Errors excepted.

NOVASONAR AK 60 Stereo

Invisible sound system for acoustic ceilings



Building material and the sound system from a single production source



Available in the following acoustic boards

Expanded glass granulate, mineral wool, glass wool, wood wool, chipped wood, etc. in all usual versions

Description / Technical data

Flat-panel loudspeaker on the principle of the bending wave transducer with a flat panel membrane, which is brought to vibration by electrical exciters mounted to the back and dual channel input for stereo applications.

The loudspeaker comprises a conventional acoustic board, e.g. made of expanded glass granulate, mineral wool, glass wool, wood wool, particle wood etc. with a factory-integrated flat-panel loudspeaker.

The acoustic board is stripped down to a minimum thickness on the back in the area of the loudspeaker membrane by means of milling and thus causes sound-neutrality.

Materials and assembly do not differ from other construction materials used and as a result, there are no „alien bodies“ in the acoustic ceiling.

Factory integration of the flat-panel loudspeaker in the building material precludes any errors in installation and guarantees continuously assembly and processing technology in drywall work without material change, therefore ensuring smooth progress on the building site.

The surface can be coated with all usual acoustic coatings.

Dimensions (standard):	Minimum 500 mm x 625 mm
Building material:	Acoustic board
Frequency response:	80 Hz – 20000 Hz
EQ:	External
Dispersion:	180° x 180°
Power handling:	2 x 30 W / 2 x 8 Ω
Optional:	70/100 V
Sensitivity:	83 dB (1 w / 1 m)
Max. SPL:	101 dB (1 m)

Manufacturer: ML-Audio und Carbons GmbH
Model: Novasonar AK 60 Stereo

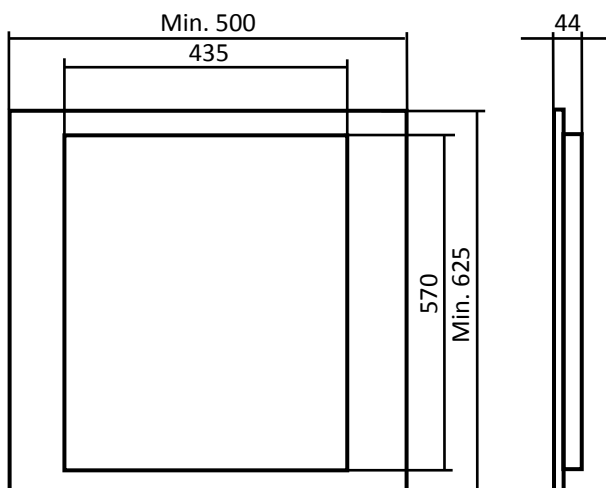
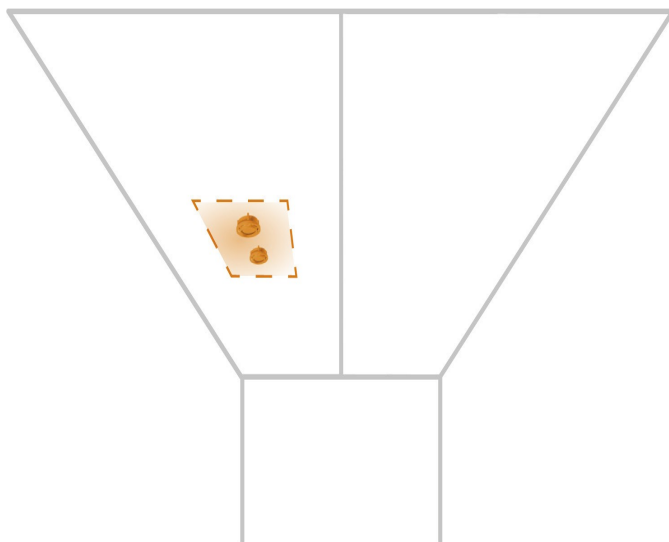

[Back to contents](#)

All products subject to technical modification without prior notice. Errors excepted.

NOVASONAR AK 60 Stereo / PN

Invisible sound system for acoustic ceilings



Building material and the sound system from a single production source



Available in the following acoustic boards

Expanded glass granulate, mineral wool, glass wool, wood wool, chipped wood, etc. in all usual versions

Description / Technical data

Flat-panel loudspeaker on the principle of the bending wave transducer with a flat panel membrane, which is brought to vibration by electrical exciters mounted to the back and with two integrated frequency crossovers/filters for dual channel input for stereo applications.

The loudspeaker comprises a conventional acoustic board, e.g. made of expanded glass granulate, mineral wool, glass wool, wood wool, particle wood etc. with a factory-integrated flat-panel loudspeaker.

The acoustic board is stripped down to a minimum thickness on the back in the area of the loudspeaker membrane by means of milling and thus causes sound-neutrality.

Materials and assembly do not differ from other construction materials used and as a result, there are no „alien bodies“ in the acoustic ceiling.

Factory integration of the flat-panel loudspeaker in the building material precludes any errors in installation and guarantees continuously assembly and processing technology in drywall work without material change, therefore ensuring smooth progress on the building site.

The surface can be coated with all usual acoustic coatings.

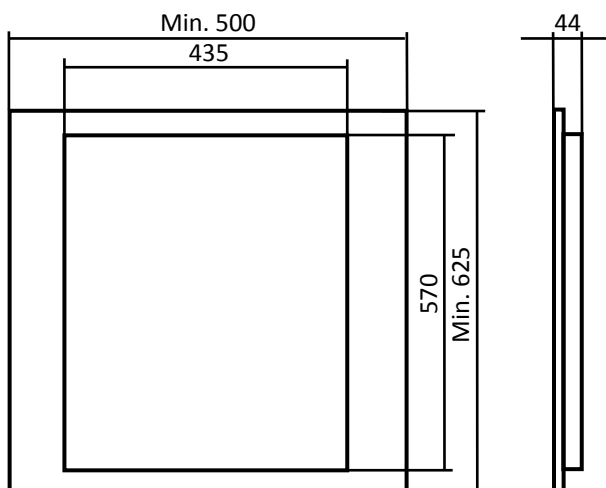
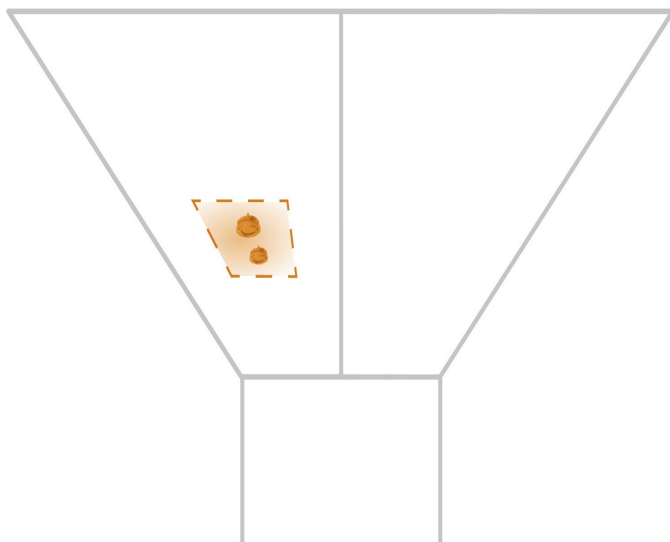

Dimensions (standard):	Minimum 500 mm x 625 mm
Building material:	Acoustic board
Frequency response:	80 Hz – 20000 Hz
EQ:	PN– integrated crossovers
Dispersion:	180° x 180°
Power handling:	2 x 30 W / 2 x 8 Ω
Optional:	70/100 V
Sensitivity:	83 dB (1 w / 1 m)
Max. SPL:	101 dB (1 m)

Manufacturer: ML-Audio und Carbons GmbH
Model: Novasonar AK 60 Stereo / PN

NOVASONAR Invisible Sound System

WITH THE INTELLIGENT INTEGRATION CONCEPT FOR A PERFECT INSTALLATION



ML-Audio und Carbons GmbH

Lautsprechertechnik

Am Hemel 2 A

55124 Mainz

Germany

Tel. +49 6 131 60 30 723

Fax +49 6 131 60 30 796

Email: info@mlaudio.de

[Back to contents](#)

Data sheets valid from 2019/09/01



AK-Series

For jointless acoustic ceilings



NOVASONAR - Invisible loudspeaker

AK-Series



Power handling: 30 Watts

Dimensions: Min. 500 mm x 625 mm

AK 30 (Ext. DSP recommended)

AK 30 / PN (Incl. frequency crossover)

Power handling: 60 Watts

Dimensions: Min. 500 mm x 625 mm

AK 60 (Ext. DSP recommended)

AK 60 / PN (Incl. frequency crossover)

AK 60 Stereo (Ext. DSP recommended)

AK 60 Stereo / PN (Incl. frequency crossover)

PN = Integrated frequency crossover

Available in the following acoustic boards:

Expanded glass granulate, mineral wool, glass wool, wood wool, chipped wood, etc. in all usual versions.

www.novasonar.de

Product overview